

EVI 5P/13

DIN 43650 A (EN 175301-803 ISO 4400)

M3 Torque 0,4+0,6Nm

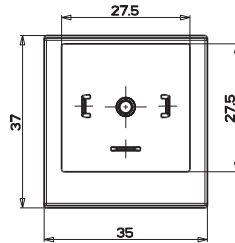
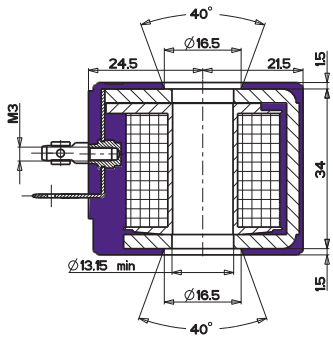

AMP JUNIOR

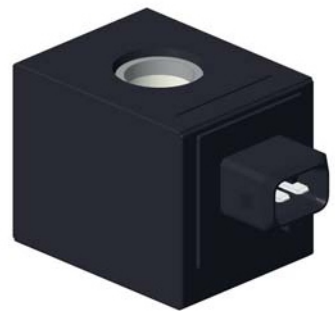
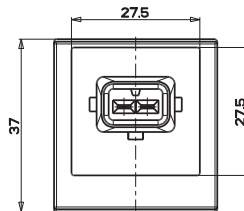
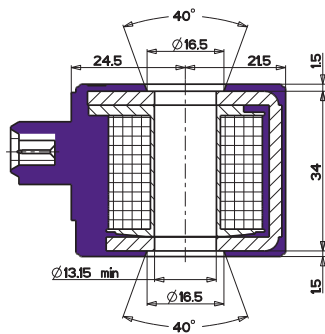

KOSTAL M27x1

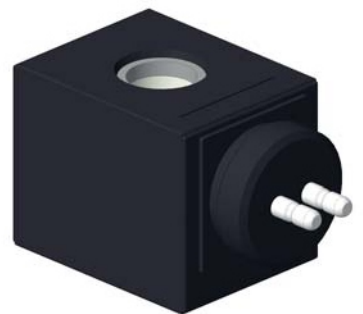
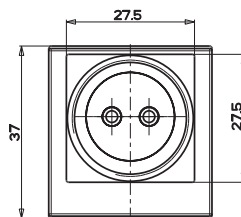
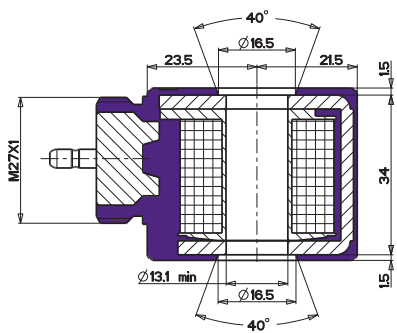

FLYING LEADS

1000 mm flying leads as a standard, AWG 18 UL Style 3173

